

SM Reel Dimensions

All dimensions in inches (mm). Weights in pounds (Kg.)

SM Gear Drive Reels

SM32 Gear Drive Reel Only

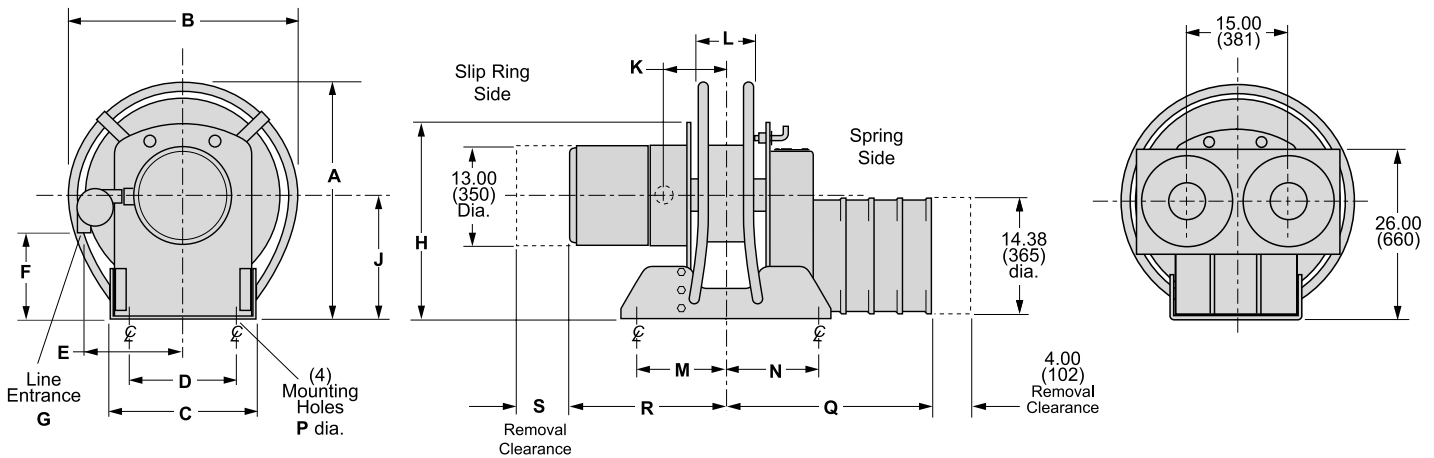

SERIES	A	B	C	D	E	F	G	H	J	K	L	M	N	P
SM 21 GEAR DRIVE 21" dia. spool	27.88 (708)	25.00 (635)	18.00 (457)	14.00 (356)	14.00 (356)	9.81 (249)	1.50 NPT	24.38 (620)	15.38 (391)	7.56 (192)	6.88 (175)	11.62 (295)	11.50 (292)	.81 dia. (21)
SM 24 GEAR DRIVE 24" dia. spool	29.38 (746)	28.00 (711)	18.00 (457)	14.00 (356)	14.00 (356)	9.81 (249)	1.50 NPT	24.38 (620)	15.38 (391)	7.56 (192)	6.88 (175)	11.62 (295)	11.50 (292)	.81 dia. (21)
SM 28 GEAR DRIVE 28" dia. spool	32.00 (813)	32.00 (813)	20.00 (508)	16.00 (406)	14.25 (362)	10.75 (293)	2.00 NPT	27.00 (686)	16.00 (406)	8.56 (218)	8.88 (226)	13.62 (346)	13.50 (343)	1.06 dia. (27)
SM32 GEAR DRIVE 32" dia. spool	36.00 (914)	36.00 (914)	20.00 (508)	16.00 (406)	14.25 (362)	12.75 (324)	2.00 NPT	29.00 (757)	18.00 (458)	8.56 (218)	8.88 (226)	13.62 (346)	13.50 (343)	1.06 dia. (27)

SPRING MOTORS

(Dimensions and Approximate Weights of Reel with Spring shown)

SERIES	1001		1002		1003		1004		1005		1006		1007		1008	
	Q	WGT.	Q	WGT.	Q	WGT.	Q	WGT.	Q	WGT.	Q	WGT.	Q	WGT.	Q	WGT.
SM 21 GEAR DRIVE 21" dia. spool	14.88 (378)	395 (179)	18.25 (464)	460 (209)	21.62 (549)	525 (238)	25.00 (635)	590 (268)	na -	na -	na -	na -	na -	na -	na -	na -
SM 24 GEAR DRIVE 24" dia. spool	14.88 (378)	405 (184)	18.25 (464)	470 (213)	21.62 (549)	535 (243)	25.00 (635)	600 (272)	na -	na -	na -	na -	na -	na -	na -	na -
SM 28 GEAR DRIVE 28" dia. spool	15.88 (403)	480 (218)	19.25 (489)	545 (247)	22.62 (575)	610 (277)	26.00 (660)	675 (306)	na -	na -	na -	na -	na -	na -	na -	na -
SM32 GEAR DRIVE 32" dia. spool	15.88 (403)	550 (250)	19.25 (489)	600 (272)	22.62 (575)	650 (295)	26.00 (660)	700 (318)	22.62 (575)	800 (363)	22.62 (575)	850 (386)	26.00 (660)	930 (422)	26.00 (660)	980 (445)

SLIP RING HOUSING DIMENSIONS

Slip Ring Model
(Second Series
of Digits
in Model Number)

23	27	103	143	320
33	37	123	163	420
43	47	312	220	
63	212	412		
83				

"R" Dimension (Series 21 & 24)	20.75(527)	23.75(603)	25.75(654)	30.25(768)
"R" Dimension (Series 28 & 32)	21.75(553)	24.75(629)	26.75(680)	31.25(794)
"S" Dimension (Series 21 & 24)	11.75(299)	14.75(375)	16.75(426)	21.25(540)
"S" Dimension (Series 28 & 32)	13.75(349)	16.75(426)	18.75(476)	23.25(591)

CABLE GUIDE DIMENSIONS AND PART NUMBERS

REEL SERIES	VERTICAL UP CABLE GUIDE			HORIZONTAL CABLE GUIDE			VERTICAL DOWN CABLE GUIDE	
	W	V	Part No.	X	Y	Part No.	Z	Part No.
SM 21	6.38 (162)	31.38 (797)	015988	17.00 (432)	6.38 (162)	015988	14.25 (362)	015989
SM 24	7.00 (178)	33.38 (848)	015988	18.00 (457)	7.00 (178)	015988	14.25 (362)	015989
SM 28	8.25 (210)	35.50 (902)	015991	19.50 (495)	8.25 (210)	015991	15.25 (387)	015992
SM 32	9.38 (236)	35.75 (984)	015991	20.75 (527)	9.38 (236)	015991	15.25 (387)	015992

OPTIONAL ACCESSORIES

