

STEP 7

DIMENSION DRAWINGS – TMR SERIES - MONOSPIRAL WRAP

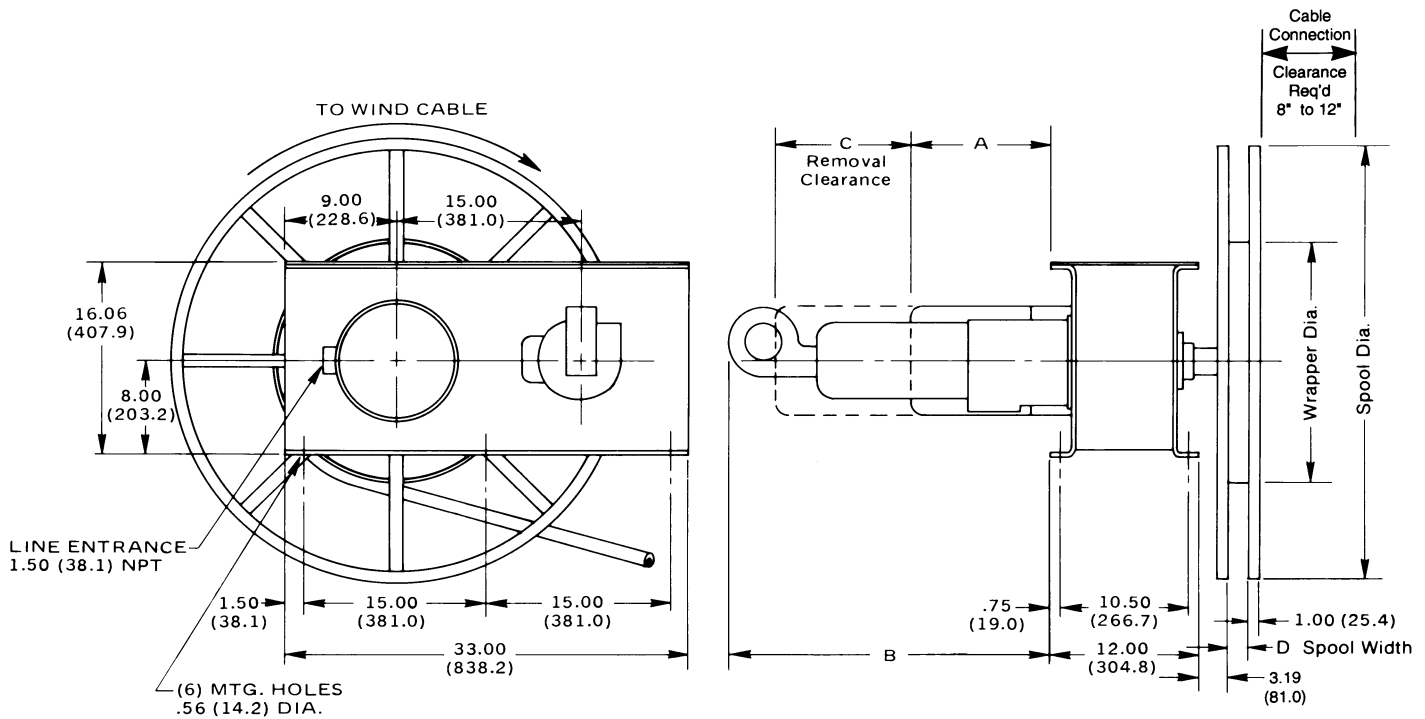

Slip Ring Housing Dimensions

| Second Series of Digits in Model Number | 23 | 63 | 103 | 143 | 203 | 303 | |
|---|-------------|-------------|-------------|-------------|-------------|-------------|-------------|
| | | 33 | 83 | 123 | 163 | 243 | 363 |
| | 43 | 27 | 312 | 412 | | | |
| | | 37 | | | | | |
| | | 47 | | | | | |
| | | 212 | | | | | |
| | | 220 | | | | | |
| | | 320 | | | | | |
| | | 420 | | | | | |
| "A" Dimension | inches (mm) | 10.69 (272) | 13.19 (335) | 15.69 (399) | 18.19 (462) | 23.19 (589) | 30.19 (767) |
| "C" Dimension | inches (mm) | 8.50 (216) | 11.00 (279) | 13.50 (343) | 16.00 (406) | 21.00 (533) | 29.00 (737) |

| "D" Dimension Monospiral Widths | | |
|--|-------|------|
| Code | Width | |
| | in | (mm) |
| MA | 0.75 | (19) |
| MB | 1.00 | (25) |
| MC | 1.25 | (32) |
| MD | 1.50 | (38) |
| ME | 1.75 | (44) |
| MF | 2.00 | (51) |

Motor Dimensions

| Last Series of Digits in Model Number | 2 | 3 | 5 | 8 | 10 | 14 | |
|---------------------------------------|-------------|-------------|-------------|-------------|-------------|-------------|--------------|
| "B" Dimension | inches (mm) | 26.55 (674) | 27.75 (705) | 30.54 (776) | 34.98 (888) | 37.11 (943) | 39.79 (1011) |
| Approximate Net Weight | lbs. (kg) | 585 (265) | 600 (272) | 615 (279) | 630 (286) | 645 (293) | 660 (299) |

DIMENSION DRAWINGS – TMR SERIES - RANDOM WRAP

STEP 7

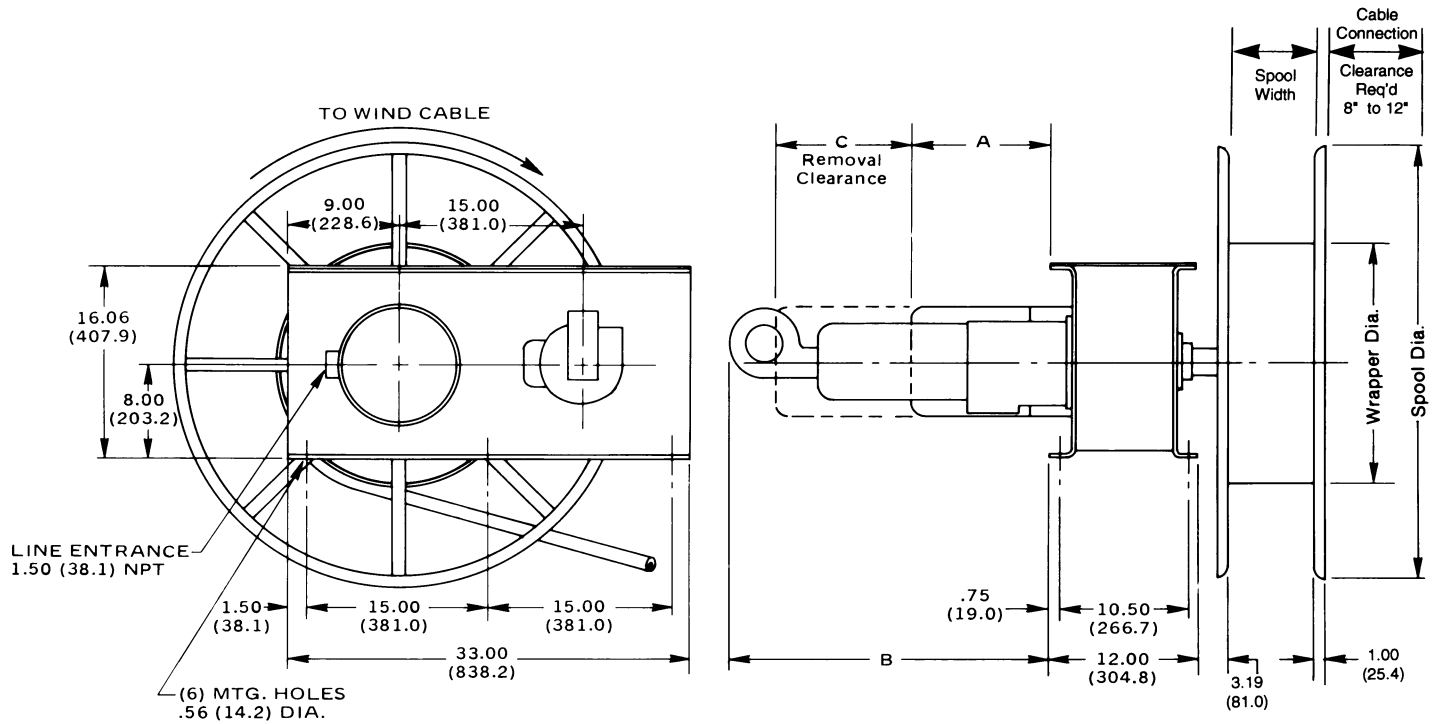

Slip Ring Housing Dimensions

| Second Series of Digits in Model Number | Model Numbers | | | | | | |
|---|---------------|-------|-------|-------|-------|-------|-------|
| | 23 | 63 | 103 | 143 | 203 | 303 | |
| | 33 | 83 | 123 | 163 | 243 | 363 | |
| | 43 | 27 | 312 | 412 | | | |
| | | 37 | | | | | |
| | | 47 | | | | | |
| | | 212 | | | | | |
| | | 220 | | | | | |
| | | 320 | | | | | |
| | | 420 | | | | | |
| "A" Dimension | inches | 10.69 | 13.19 | 15.69 | 18.19 | 23.19 | 30.19 |
| | (mm) | (272) | (335) | (399) | (462) | (589) | (767) |
| "C" Dimension | inches | 8.50 | 11.00 | 13.50 | 16.00 | 21.00 | 29.00 |
| | (mm) | (216) | (279) | (343) | (406) | (533) | (737) |

Motor Dimensions

| Last Series of Digits in Model Number | | 2 | 3 | 5 | 8 | 10 | 14 |
|---------------------------------------|--------|-------|-------|-------|-------|-------|--------|
| "B" Dimension | inches | 26.55 | 27.75 | 30.54 | 34.98 | 37.11 | 39.79 |
| | (mm) | (674) | (705) | (776) | (888) | (943) | (1011) |
| Approximate Net Weight | lbs. | 585 | 600 | 615 | 630 | 645 | 660 |
| | (kg) | (265) | (272) | (279) | (286) | (293) | (299) |