



PDQ 300 FESTOON SYSTEM

INSTALLATION AND MAINTENANCE INSTRUCTIONS

INTRODUCTION

The PDQ Festoon System was designed to run on one of three sizes of I-beams: S3 x 5.7, S4 x 7.7, S6 x 12.5. System trolleys must have been ordered for the size I-beam intended for use or the trolleys will not fit. If your I-beam is not one of those listed above, contact the Gleason Reel factory or your local Gleason representative. Maximum capacity is 300 lbs. per trolley at 400 fpm.

Each installation includes one fixed trolley, one tow trolley, and a number of intermediate trolleys. Refer to Figure 1-Typical Installation and Figure 4-Trolley Components and thoroughly familiarize yourself with this product and the terminology used prior to beginning installation.

NOTICE: Safe and proper operation and long life of the PDQ Festoon system depend on proper installation, maintenance, location and environment. These instructions are intended as a guide but do not cover all possible situations that may arise. Please refer any questions to Gleason Reel or its authorized representative or distributor.

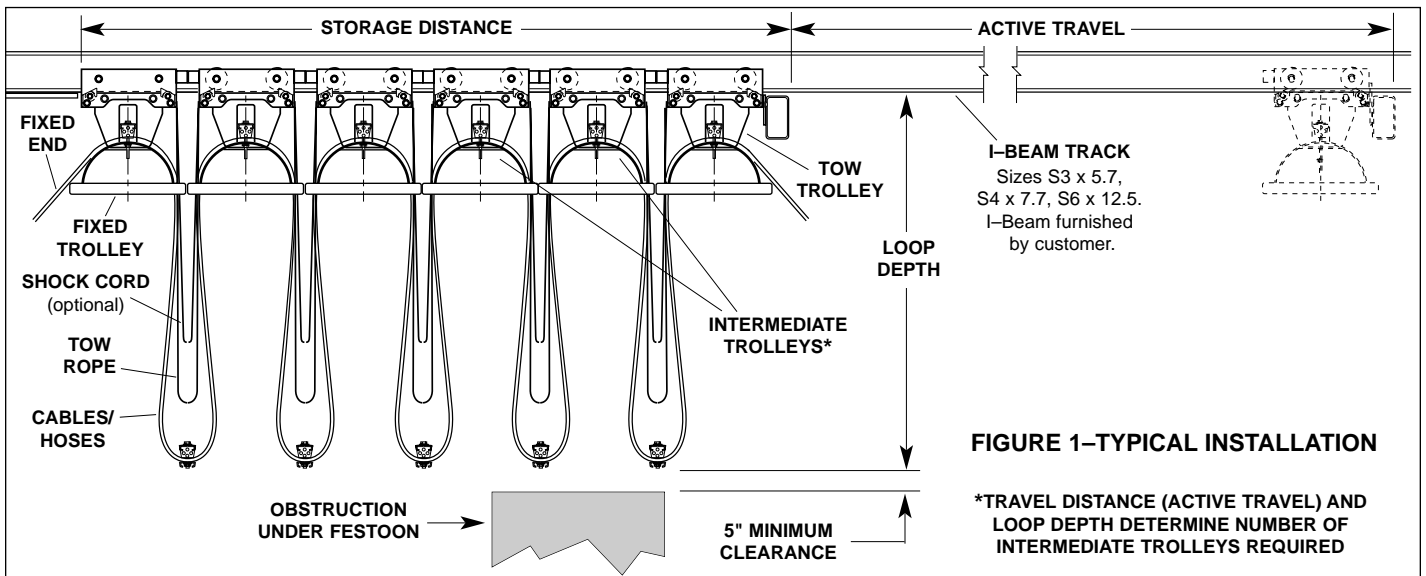

I-BEAM TRACK INSTALLATION

1. Mount I-beam track to any suitable framework that is strong enough to support the entire weight of the festoon system (weight of I-beam, hanging hardware, trolleys and cables or hoses which will be carried by the festoon). Make sure hardware used for hanging I-beam will not interfere with free trolley movement. Refer to Figure 2-Trolley Clearance.

NOTE:

On previously installed track, check all joints and hangers for clearances shown in Figure 2.

2. Special care should be taken in aligning the I-beam sections to the crane or hoist support rails. I-beams must be parallel with rails.

ACCEPTABLE SYSTEM TOLERANCES:

HORIZONTAL PLANE: 0.02" per 1.0" across the lower flange width.
 RISE/RUN RATIO: 1.0" per 10.0' along track length, maximum of 2.0" for entire SYSTEM LENGTH.

3. Join beams by welding, keeping clearances shown in Figures 2, & 3. Use beams having the same lower flange tolerances. Grind welded joints smooth as shown in Figure 3.

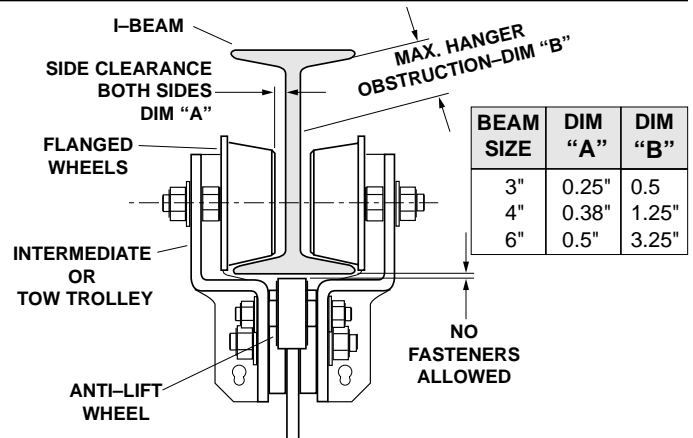

FIGURE 2-TROLLEY CLEARANCE

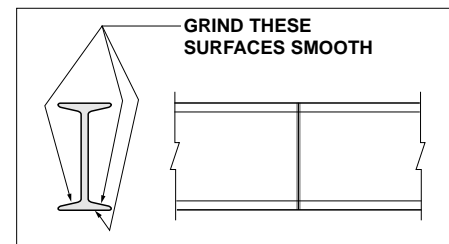

FIG 3-WELDED JOINT

TROLLEY INSTALLATION

There are three types of trolleys: Fixed, Intermediate, and Tow. The **FIXED** trolley is the first trolley on the storage end of the system. It is stationary, bolted to the track, and acts as the “bumper” to stop the trolleys when they are moved into storage. See Figure 1–Typical Installation. **INTERMEDIATE** trolleys carry the cable or hose. Number and spacing of intermediate trolleys is determined by length of cable/hose and loop depth. The **TOW** trolley is last in the string and is attached to the machine (crane, machine tool, etc.) serviced by the festoon system.

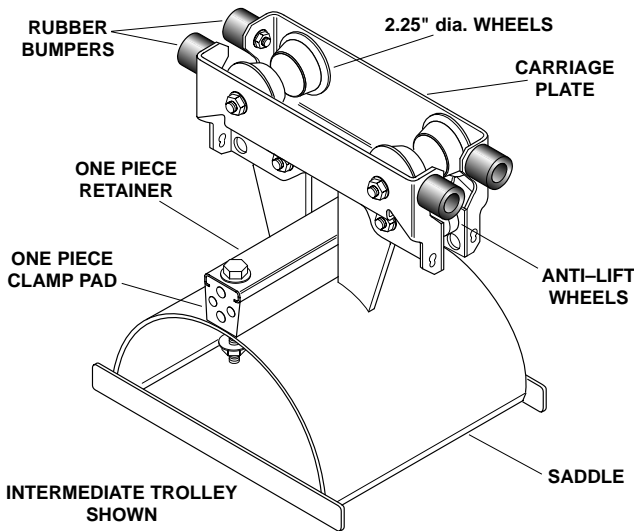

FIGURE 4–TROLLEY COMPONENTS

1. Check to make sure all trolleys are sized for I-beam installed previously. No width adjustment is required or possible. If trolleys do not fit I-beam, consult factory or Gleason representative.
2. Slide all trolleys onto I-beam track in order shown in Figure 1.
NOTE: Fixed trolley will rest on cut-outs in carriage plates.
3. Temporarily position trolleys as they will be stored. There should be 1/8" between bumpers. Tow trolley must be at or beyond limits of machine movement.
4. Fasten **FIXED TROLLEY** to I-beam.

A. Temporarily slide fixed trolley out of the way.

B. Mark vertical location of mounting holes on beam web, 1.2" above bottom of I-beam. One method of doing this is by using two squares as shown in Figure 5.

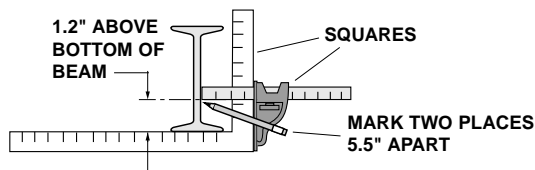

FIGURE 5–LOCATING FIXED TROLLEY HOLES

C. Mark horizontal location of holes. Holes must be 5.5" apart and in final location for fixed trolley. Drill two 0.562" dia. holes thru web. See Figure 6.

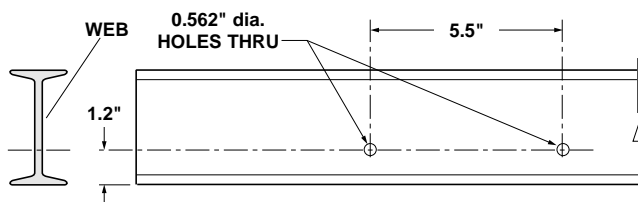

FIGURE 6–BEAM DRILLING

D. Mount fixed trolley to I-beam using hex head bolt, flat washers, spacers and lock nut, supplied. See Figure 7.

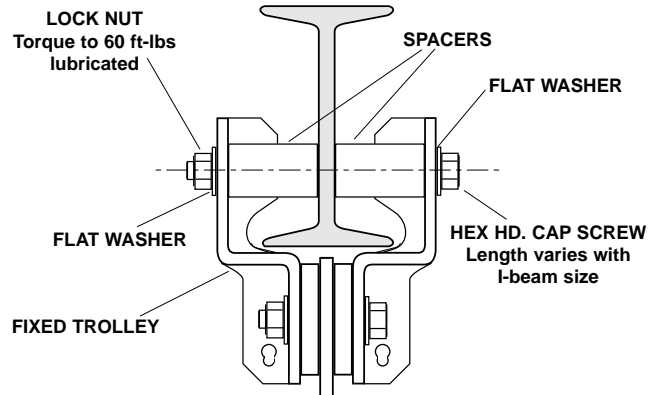

FIGURE 7–SECURING FIXED TROLLEY

E. Weld or bolt a thrust bar to I-beam directly behind the fixed trolley to absorb impact forces. See Figure 8.

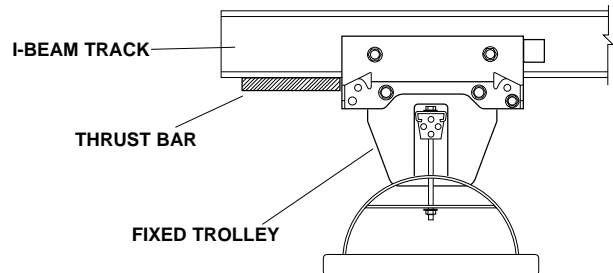

FIGURE 8–FIXED TROLLEY THRUST BAR

6. Remove temporary restraints securing trolleys in storage position (Step 3).
7. Roll all wheeled trolleys along entire length of track. Check for binding or interference from hanging or joining hardware or weld bead. Fix areas of concern.
8. Set clearances for **TOW** trolley. NOTE: Tow arm is supplied by customer and must work to minimum clearances of rectangular tube. Check tow arm movement throughout total system travel to insure it does not pull out of rectangular tube in tow trolley and that no upward or downward forces are transmitted to tow trolley. See Fig. 9.

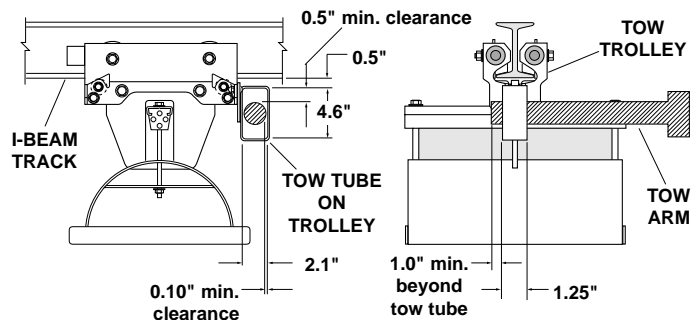

FIGURE 9–TOW ARM CLEARANCE

CABLE INSTALLATION

Proper cable installation is the key to a successful festoon system. Refer to the guidelines below while following the cable installation procedure.



CABLE GUIDELINES

Bending Cables
It is best to follow the rule that "BIG BENDS ARE BEST" for good service and long life. Cable manufacturers vary in applying a multiplier and we offer the following guide as typical. Gleason uses the chart below.

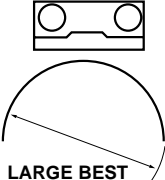
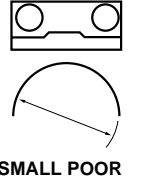
CABLE O.D.	MINIMUM RADIUS	MINIMUM SADDLE DIA.
Under 0.3 in.	3 x O.D.	6 x O.D.
Under 0.5 in.	4 x O.D.	8 x O.D.
Under 0.8 in.	5 x O.D.	10 x O.D.

Cable O.D. Variations
Variations should be kept to a minimum. Clamping is best accomplished when all cables are same O.D. or close (Figure 10). Wide deviation (Figure 11) makes clamping difficult and cable may not remain in saddle.

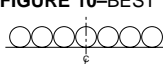
Balance in Loading Cable
This is important for smooth running, long wheel bearing life and alignment of components. It is best to distribute the cable evenly, with the heaviest cables near the center.

Flat Cable Stacking

A. Secure clamping
EXTREMELY IMPORTANT: At least 50% of cable surface must be under clamp pressure.

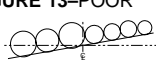





FIGURE 14 BEST
100% clamping

FIGURE 15 GOOD
50% clamping

FIGURE 16 POOR

B. Height consideration
Flat cable stacking best when width is 3-4 times height, as in Figures 14 & 15 above. High stacking can work as long as equal pressure is applied to all cables. See Figure 17.



FIGURE 17
OK

C. Configuration
BIG CABLE ON TOP provides maximum bending radius, improves heat dissipation and takes pulling force when tow cables are not used. See Fig. 18.

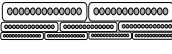

FIGURE 18
BEST

Cable Layout when General Arrangement Drawing is provided.

1. Remove all twist from round cable.
2. On cable, mark length required between TOW trolley and termination junction.
3. Mark CABLE LENGTH LOOPS per General Arrangement Drawing. Remaining cable is for hookup from FIXED trolley to termination point.
4. Hang cable. All marks on cable must align with tops of saddles. See Figure 19. Arrange multiple cables per General Arrangement Drawing.

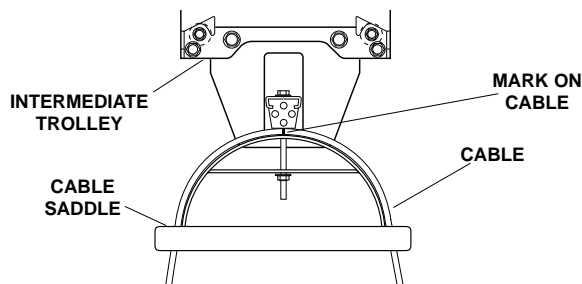

FIGURE 19—ALIGNING CABLE MARKS

5. Complete cable termination connections after loops have been adjusted and loop clamps installed. Avoid connections or splices at any loop between TOW trolley and FIXED trolley.
6. After cable loop(s) is aligned, clamp cables in place using cable clamps on the saddle. Cable clamps should be tightened so that the smallest cable cannot be pulled through by hand.
7. Install CABLE LOOP CLAMPS at bottom of each single layered loop. Tighten. **NOTE: Flat cable may be "stacked" (see CABLE GUIDELINES, above). If cable is stacked, adjust loops as shown in CABLE LOOP ADJUSTMENTS section, right.**

Cable Layout when no General Arrangement Drawing is provided.

1. On cable, mark length required between TOW trolley and termination junction.
2. Mark length required from FIXED trolley to termination point.

3. Divide remaining cable into equal lengths per number of CABLE LOOPS and mark each length.

$$\text{NUMBER OF CABLE LOOPS} = \text{NUMBER OF INTERMEDIATE TROLLEYS} + 1$$

4. Hang cable. All marks on cable must align with tops of saddles. See Figure 19. Arrange multiple cables using guidelines above.
5. Complete cable termination connections after loops have been adjusted and loop clamps installed. Avoid connections or splices at any loop between TOW trolley and FIXED trolley.
6. After cable loop(s) is aligned, clamp cables in place using cable clamps on the saddle. Cable clamps should be tightened so that the smallest cable cannot be pulled through by hand.
7. Install CABLE LOOP CLAMPS at bottom of each loop. Tighten. **NOTE: Flat cable may be "stacked" (see CABLE GUIDELINES, above). If cable is stacked:**
 - A. If you received one cable clamp per loop, arrange cables as indicated above.
 - B. If you received two cable clamps per loop, adjust loops as shown in CABLE LOOP ADJUSTMENTS section, below.

Cable Loop Adjustments (For two or more layers of flat cable)

1. Starting at the Tow Trolley, loosen cable clamp on FIRST intermediate trolley.
2. Without shifting the lowest layer of cable, shorten each successive layer of cables upward in the loop to create a space of approximately 1/4". See Figure 20.
3. Reclamp cables and make certain that the smallest cable cannot shift or be pulled through by hand.
4. Adjust each cable loop in the same manner as described in steps 2 & 3. Continue these procedures, working toward the Fixed Trolley.
5. Cut the cables to the correct length at the Fixed Trolley termination junction.

6. Install cable loop clamps (two per loop).

- A. Locate cable clamps approximately half way down each side of loop.
- B. Stagger clamps as shown in Figure 20 to prevent them from colliding with each other during system operation.

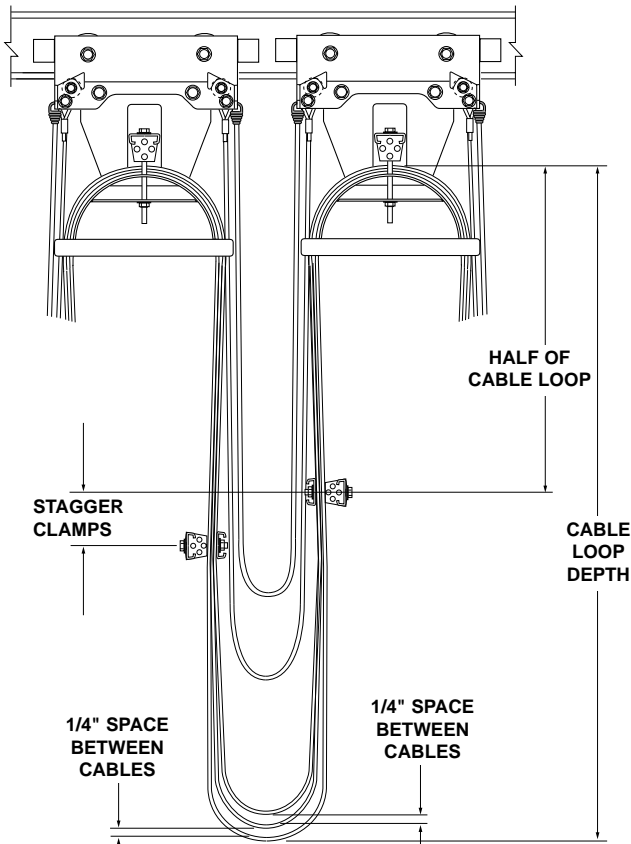

FIGURE 20—CABLE LOOP ADJUSTMENT

INSTALLING TOW ROPES

Tow ropes “pull” the festoon system along the track, minimizing wear to and prolonging the life of electrical cables or hoses being carried.

Without tow ropes, the electrical cables are required to act as tension members which can lead to separated conductors. On multiple cable applications it is virtually impossible to adjust a festoon system so that all cables are exactly the same length. Thus all force is directed to the shortest cable, further compounding the problem. Tow ropes are slightly shorter than the cables in each loop and no strain is put on the electrical cables or hoses themselves. See Figure 1—Typical Installation.

- 1. Mount tow ropes with fasteners supplied. See Figure 21.

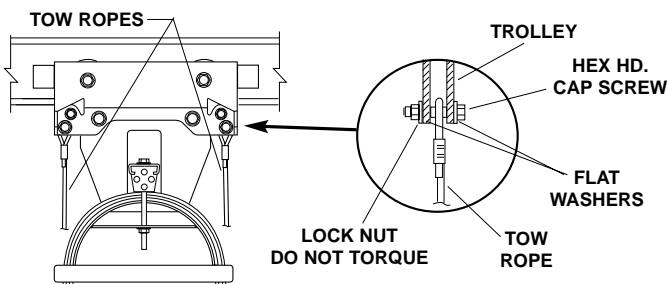

FIGURE 21—TOW ROPE INSTALLATION

INSTALLING SHOCK CORDS

(when required)

Shock Cords are slightly shorter than tow cables and are used in pairs...two between each trolley. Spring loaded, their function is just as their name implies; they act as shock absorbers when the festoon trolleys are beginning to move, limiting undue stress on the tow ropes.

- 1. Mount two shock cords between each pair of trolleys as shown in Figure 22.

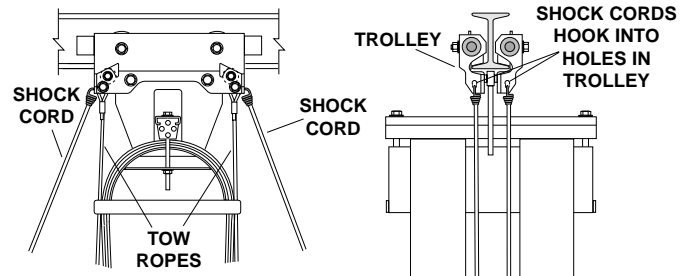

FIGURE 22—SHOCK CORD INSTALLATION

TESTING

- 1. With tow arm **not** attached to tow trolley, spread each set of trolleys and check to make sure tow rope gets tight before electrical cables or hoses. Adjust length of cable or hose loop, as required.
- 2. Spread each set of trolleys and check to make sure shock cords are stretched before tow rope gets tight.
- 3. Connect tow arm to tow trolley and **slowly** operate festoon system throughout the total travel. Check for “smooth rolling wheels”, misaligned joints, hanging or joining hardware interference, and interference of cable loops with operating area.
- 4. With festoon trolleys in **STORAGE POSITION**, check to see that intermediate trolleys can move back and forth slightly. They must not be packed “tight” when tow arm is at end of travel.
- 5. With festoon system **FULLY EXTENDED**, check each loop to see that cables are suspended uniformly between trolleys and that cable load is balanced in saddle.
- 6. Correct all problems before routine operation of crane or hoist.

MAINTENANCE

- 1. During normal equipment inspection, perform the following checks and maintenance:
 - A. Check for wear on trolley wheels and anti-lift rollers. Wheel and anti-lift roller bearings are sealed and do not require routine maintenance.
 - B. Check for loose fasteners and nuts, especially the bolts affixing the fixed trolley to the I-beam. Tighten if required.
 - C. Check for wear or fractured walls on the rectangular tube on the tow trolley. Repair or replace as necessary. If undue wear persists, check alignment of tow arm throughout entire travel. Refer to **TROLLEY INSTALLATION**, Step 8.
 - D. Check condition of bumpers, tow ropes and shock cords. Replace as required.
 - E. Check for damaged cable and the tightness of cable and loop clamps.

PDQ 300 FESTOON SYSTEM

ILLUSTRATED PARTS LIST

This illustrated parts list was designed to serve both as a source for repair parts and as a guide for repair and replacement. For more details see appropriate section elsewhere in this INSTALLATION AND MAINTENANCE instruction booklet. Note that many items are available only as repair kits. These kits usually include all related hardware as well as the primary part. For example, kit number 039487 contains the wheel and also the washer and lock nut required to affix the wheel to the trolley. Common hardware not contained in a kit does not include a part number and may be purchased locally.

ITEM NO.	PART/KIT NO.	DESCRIPTION	QTY. EA. INTERMED. TROLLEY	QTY. EA. TOW TROLLEY	QTY. EA. FIXED TROLLEY
1	039750	Carriage Plate (6" dia. saddle) (9" dia. saddle) (12" dia. saddle)	2 2 2	2 — —	2 2 2
1	04152601	L.H. Carriage Plate (9" dia. saddle)	—	1	—
1	04152602	R.H. Carriage Plate (9" dia. saddle)	—	1	—
1	04152401	L.H. Carriage Plate (12" dia. saddle)	—	1	—
1	04152402	R.H. Carriage Plate (12" dia. saddle)	—	1	—
2	039769	Wheel Kit—PDQ 300 <i>Includes 2.25" dia. wheel, washer and lock nut.</i>	4*	4*	—
3	039761	Anti-lift Wheel Kit (3" I-beam) <i>Includes wheel, flat washer and lock nut.</i>	2*	2*	—
3	039762	Anti-lift Wheel Kit (4" I-beam)	2*	2*	—
3	039763	Anti-lift Wheel Kit (6" I-beam)	2*	2*	—
4	03973901	Spacer—3" I-beam	4*	4*	4*
4	03973902	Spacer—4" I-beam	4*	4*	4*
4	03973903	Spacer—6" I-beam	4*	4*	4*
5		Flat Washer, 1/2"	12	10	10
6		Lock Nut, 1/2-13	2	2	2
7		Hex Hd. Cap Screw, 1/2-13 x 2.25" lg. (3" I-beam)	2*	2*	2*
7		Hex Hd. Cap Screw, 1/2-13 x 2.50" lg. (4" I-beam)		2*	2*
2*					
7		Hex Hd. Cap Screw, 1/2-13 x 3.25" lg. (6" I-beam)	2*	2*	2*
8	039764	Bumper Kit (6" dia. saddle) <i>Includes bumper, mounting screw, washer and nut.</i>	4*	4*	4*
8	039489	Bumper Kit (9" & 12" dia. saddle) <i>Includes bumper, flat washer, hex lock nut.</i>	4*	2*	2*
9	039765	Bumper Extension Kit (12" saddle) <i>Includes spacer and hardware only. Bumper not included.</i>	4*	—	2*
10	017492	Bumper Only (9" & 12" saddles only)	4**	2**	2**
11		Lock Nut/Nylon Insert, 1/2-13	2	1	1
12		Hex Hd. Cap Screw, 1/2-13 x 2.0 (3" I-beam)	2*	1*	1*
12		Hex Hd. Cap Screw, 1/2-13 x 2.50 (4" I-beam)	2*	1*	1*
12		Hex Hd. Cap Screw, 1/2-13 x 3.25 (6" I-beam)	2*	1*	1*
13		Tow Rope (Call factory with length)	1	—	1
14		Shock Cord (Call factory with length)	2	—	2
15	03974901	Saddle Weldment, 6.0" dia. x 7.50" wide			
15	03974902	Saddle Weldment, 6.0" dia. x 9.50" wide			
15	03974903	Saddle Weldment, 6.0" dia. x 11.50" wide			
15	03974801	Saddle Weldment, 9.0" dia. x 7.50" wide			
15	03974802	Saddle Weldment, 9.0" dia. x 9.50" wide			
15	03974803	Saddle Weldment, 9.0" dia. x 11.50" wide			
15	03974701	Saddle Weldment, 12.0" dia. x 7.50" wide			
15	03974702	Saddle Weldment, 12.0" dia. x 9.50" wide			
15	03974703	Saddle Weldment, 12.0" dia. x 11.50" wide			
16	01904813	Retainer, 7.5" wide saddle	1*	1*	1*
16	01904814	Retainer, 9.5" wide saddle	1*	1*	1*
16	01904815	Retainer, 11.5" wide saddle	1*	1*	1*
17	03556013	Clamp Pad, 7.5" wide saddle	1*	1*	1*
17	03556014	Clamp Pad, 9.5" wide saddle	1*	1*	1*
17	03556015	Clamp Pad, 11.5" wide saddle	1*	1*	1*
18	01875601	Hex Hd, Cap Screw, 1/2-13 x 5" lg. (full thread) 6" dia. Saddle	2*	2*	2*
18	01875605	Hex Hd, Cap Screw, 1/2-13 x 6" lg. (full thread) 9"/12" Saddle	2*	2*	2*
19		Hex Nut, 1/2-13	2	2	2
20	039756	Tow Arm Weldment	—	1	—
21		Hex Hd. Cap Screw, 3/16"-18 x 1" lg.	—	2	—
22		Flat Washer, 3/16	—	4	—
23		ESNA Lock Nut, 3/6-18	—	2	—
24	039766	Fixing Spacer Kit (3" I-beam)	—	—	2*
24	039767	Fixing Spacer Kit (4" I-beam)	—	—	2*
24	039768	Fixing Spacer Kit (6" I-beam)	—	—	2*

One saddle needed per trolley.
Be sure to order correct size.

*Be sure to state capacity, I-beam and saddle size on order.

INTERMEDIATE TROLLEY

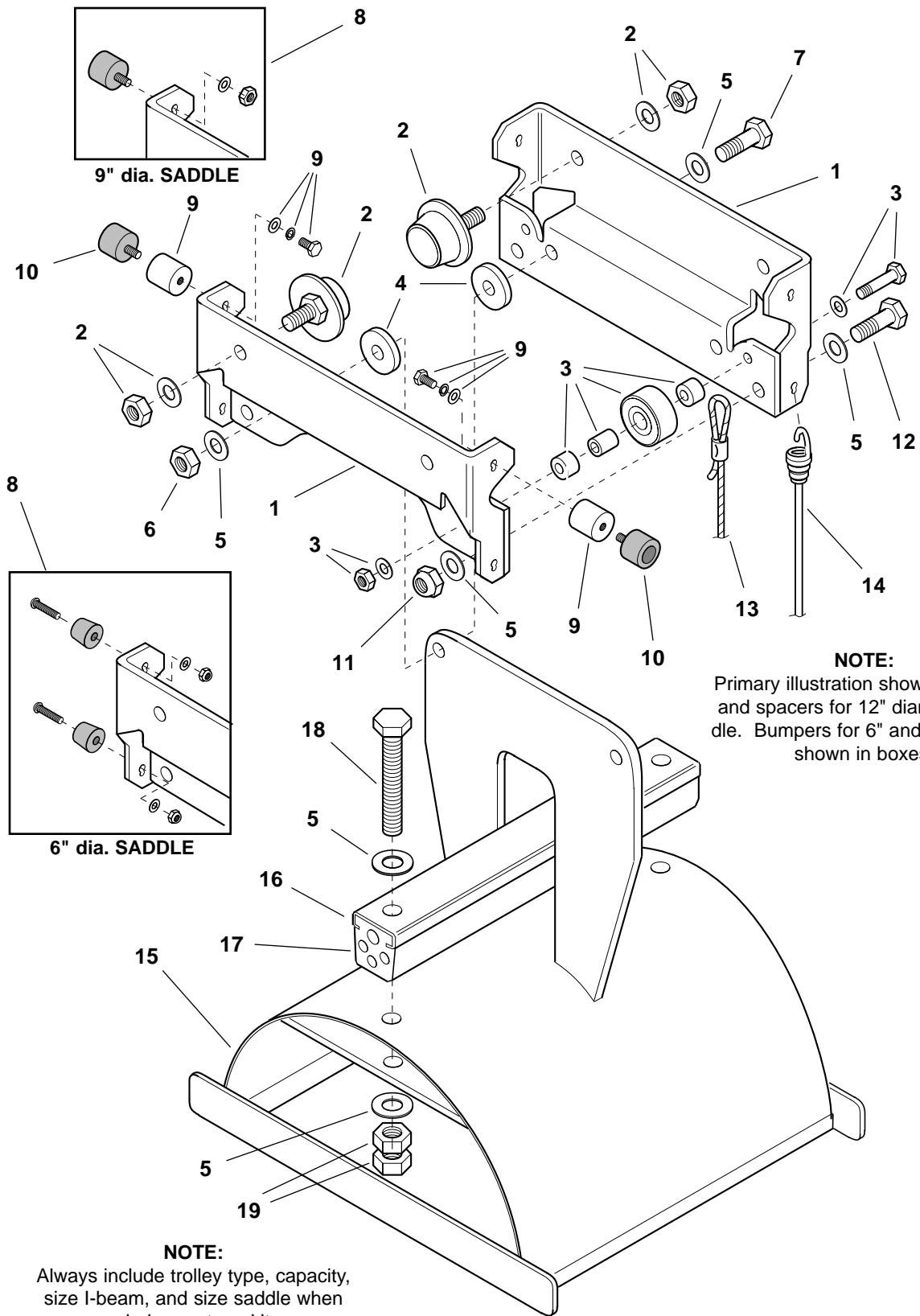

NOTE:
 Primary illustration shows bumpers and spacers for 12" diameter saddle. Bumpers for 6" and 9" saddles shown in boxes.

NOTE:
 Always include trolley type, capacity, size I-beam, and size saddle when ordering parts or kits.

TOW TROLLEY

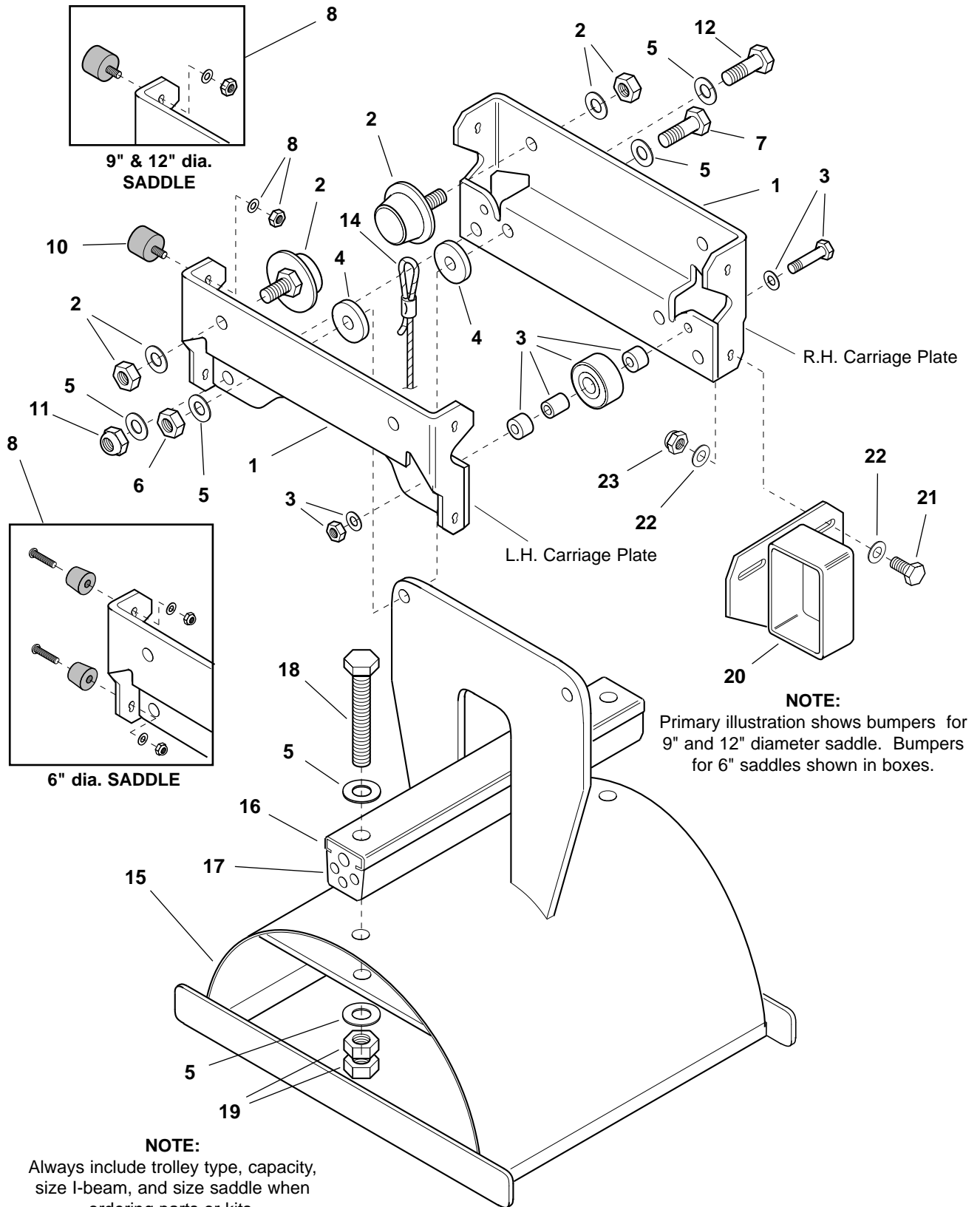

FIXED TROLLEY

NOTE:
Always include trolley type, capacity, size I-beam, and size saddle when ordering parts or kits.

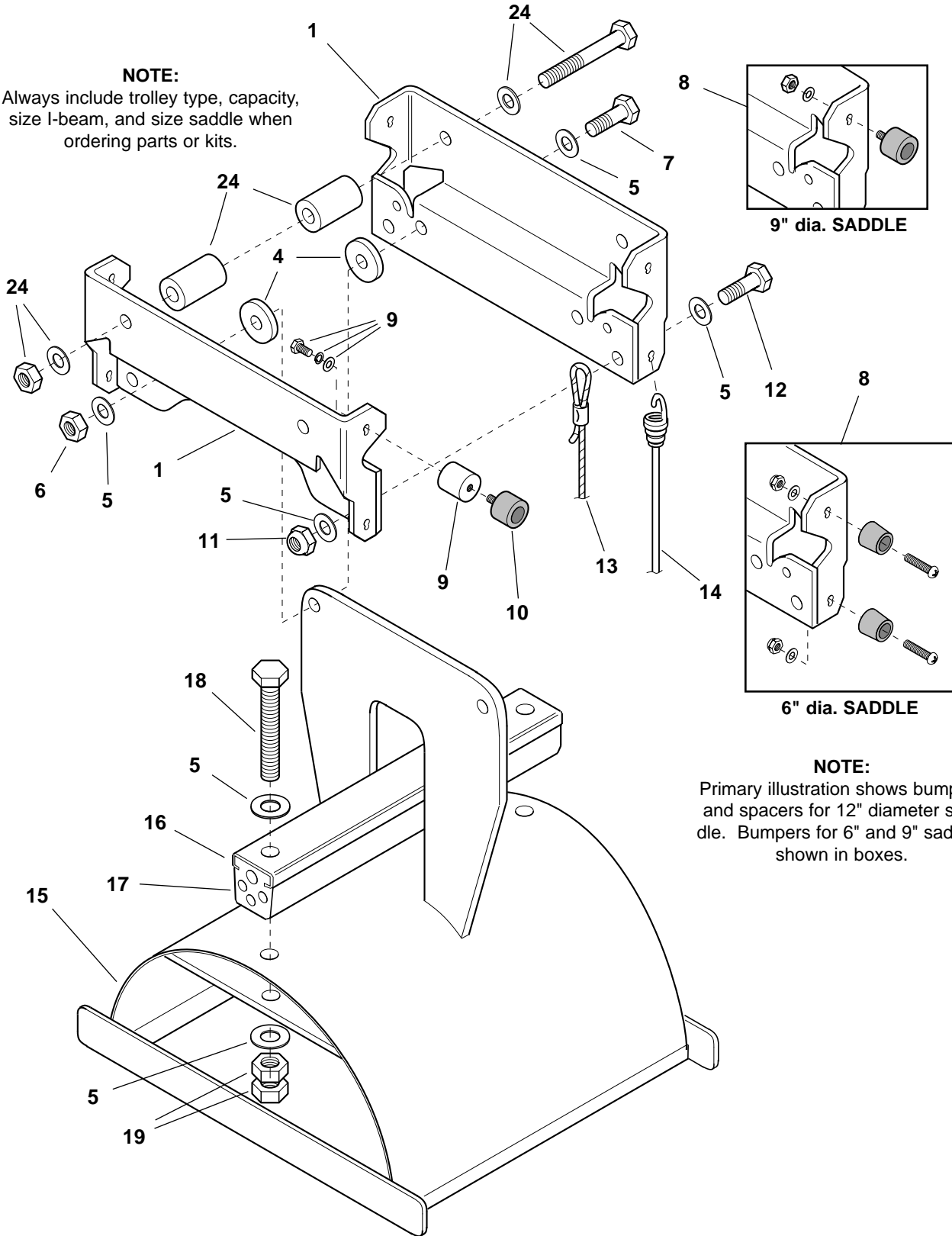

NOTE:
Primary illustration shows bumpers and spacers for 12" diameter saddle. Bumpers for 6" and 9" saddles shown in boxes.



Gleason Reel Corp.

P.O. Box 26, 600 S. Clark St.
Mayville, Wisconsin 53050-0026
Phone 920/387-4120
FAX 920/387-4189