



C-RAIL TRACK FESTOON SYSTEMS

INSTALLATION INSTRUCTIONS

INTRODUCTION

The following procedure has been established to provide the customer with a simple and accurate method of installing a Festoon System.

Please refer to the dimensional print with bill of material list for parts identification and system specifications. Various sketches are included throughout this bulletin to clarify the assembly procedure.

C-RAIL TRACK INSTALLATION

- A.1 The customer must furnish interfacing mounting brackets or other framework to support the C-Rail track. The bracket spacing requirements are specified on the system dimensional print.
- A.2 The C-Rail track installation tolerances shall be as follows:
 - A.2.1 The C-Rail slope deviation is not to exceed a rise/run ratio of 1"/10" along the rail length and .02"/1.00" across the rail width with respect to a true horizontal plane.
 - A.2.2 Gleason Reel's standard manufacturing tolerances shall apply to the C-Rail shape and camber/sweep deviations.
- A.3 The C-Rail track must be parallel to the customer's crane or hoist support rail. Deviation shall not exceed 1" in 10" of length, or 2" for the entire system length.
- A.4 Determine the distance between the centerlines of the customer's trolley rail and the C-Rail track by the formula:
$$(\text{Loop Depth [in.] X .20}) + (\text{Saddle Width X .50})$$
- A.5 The customer's support framework or brackets may be any suitable structural grade material to suspend the weight of the entire Festoon System. The recommended factor of safety is five (5).

HANGING BRACKETS AND C-RAIL TRACK (Figure 1)

- B.1 Locate the hanging brackets on the underside of the customer's support brackets with a tension line parallel to the customer's support rail at the dimension calculated per Section A, Step 4.
- B.2 Install the C-Rail section nearest the storage end of the system first. Position the rail with either sidewall adjacent to the tension line. The open side must face downward.
- B.3 Attach one hanging bracket at each end of the C-Rail section. All hanging brackets between these end positions are located with the C-Rail track. Locate the hanging brackets per the spacing requirements on the system dimensional print.
- B.4 Use the hanging bracket as a template and drill both mounting holes. Be sure the bracket opening is parallel to the tension line.
- B.5 Weld or bolt the hanging brackets in place using Grade 5 hardware or better.
- B.6 Install the hanging brackets and each successive section of C-Rail, the same as the above procedure. Each C-Rail joint will require a coupler.

NOTE: The C-Rail track must be installed in a horizontal position, unless special application specifies otherwise. This method of installing hanging brackets will compensate for any slight camber/sweep deviation of the C-Rail. Each hanging bracket may be installed using a tension line as a guide for location without utilizing the C-Rails, but difficulty in threading the rails through the brackets may result. Be sure the C-Rail open side faces downward.

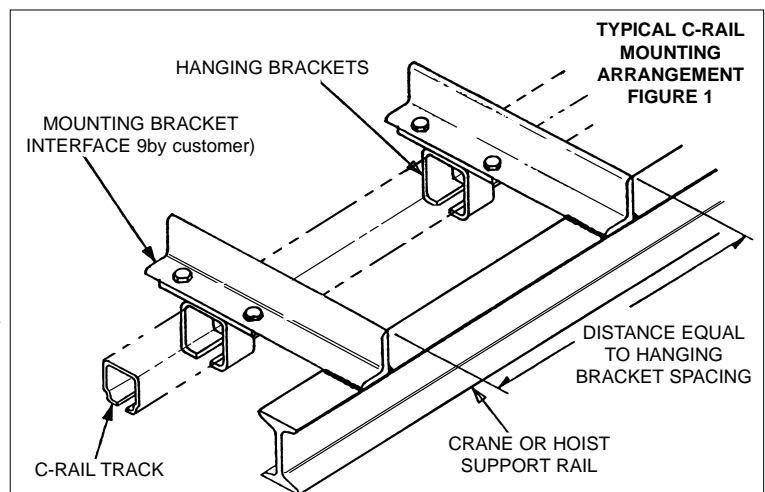

COUPLERS (Figure 2)

- C.1 Each C-Rail joint requires a coupler and must be attached as each successive C-Rail section is installed.
- C.2 Slide coupler halfway onto the end of the C-Rail with open side facing downward.
- C.3 Secure coupler in place using upper screws only. Do not lock the screws in place at this time.
- C.4 Slide adjoining C-Rail section into the coupler and tighten the upper screws.
- C.5 The C-Rail ends must be butted together tightly — 0.03" gap maximum allowed.
- C.6 The lower flange surfaces of the C-Rail joint must be coplanar. The transition across the C-Rail joint must be smooth and uniform.
- C.7 Tighten the remaining side screws, being careful not to exert too much torque which could close the rail opening and cause the trolleys to bind.
- C.8 Lock all the screws in place by tightening the hex nuts.
- C.9 Repeat this procedure for all coupler locations.

NOTE: When the C-Rail track installation is complete, take any trolley car and feed it into the C-Rail. The trolley must operate smoothly throughout the entire length of the C-Rails, particularly at all joints. No binding can be tolerated. Remove the trolley from the rails and continue with the next procedure.

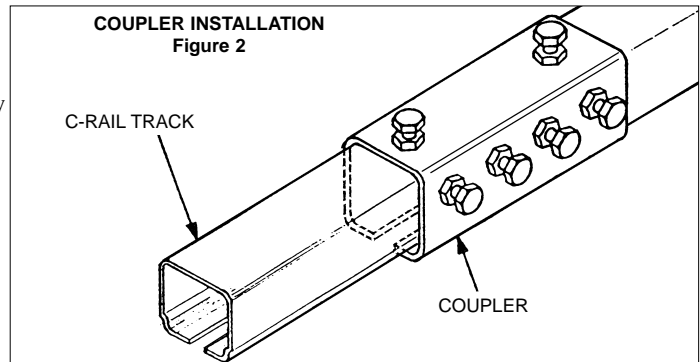

CABLE INSTALLATION (Refer to DIMENSION PRINT)

- D.1 Layout cables per the cable arrangement view on the dimension print.
- D.2 Temporarily bind together for easier handling.
- D.3 Mark the cable length required between the tow trolley and the customer's termination. This dimension is specified at the time of order and cannot be changed.
- D.4 Mark the remaining cable lengths equal to the length of cable between trolleys given on the dimension print.
- D.5 Any remaining cable is for hook-up from the end clamp to the customer's termination.
- D.6 Remove the carriage bolt(s) from one side of the saddle and attach trolleys to the cable package with the mark directly beneath the rubber clamp pad.
- D.7 Draw up saddles evenly to secure in place. Do not lock hex nuts together at this time.
- D.8 Hang the trolleys and cable on the C-Rail at the storage end of the system per the dimension print.
- D.9 Attach end clamp to rail per Section "E" on dimension print.
- D.10 Dress cable loops per Section "F" on dimension print.

END CLAMP

- E.1 Locate the end clamp on the C-Rail per the dimension print and secure.
- E.2 Depending on which model Festoon System is being installed, two holes drilled through both side walls of the C-Rail track may be required to anchor end clamp. Refer to dimension print for size and location of holes.
- E.3 If this system is for a pendant application, an auxiliary end stop will be furnished and must be installed at the far end of the C-Rail track opposite the storage end.
- E.4 End caps can now be assembled to the C-Rail track at both ends of the system.

CABLE LOOP DRESSING (For Two Layers of Cable or More—Figure 3)

- F.1 Begin at a central cable loop position and loosen the cables.
- F.2 Without shifting the lowest layer of cables, shorten each successive layer of cables upward in the loop to remove any kinks and create a space between layers of approximately 1/4 inch.

- F.3 Reclamp cable package to saddles to prevent shifting. Do not over-tighten or crush cables. Tighten all hex nuts together to lock in place.
- F.4 Dress each cable loop working toward both ends of the system per Step F.2.
- F.5 The cable package must be positioned to concentrate the center of gravity at the center of the saddle and trolley.

CABLE LOOP CLAMPS (Figure 3)

- G.1 Cable packages having three or more layers require a cable tie or clamp. Two clamps per loop are needed and must be located halfway down each side of the loop.
- G.2 The clamps should be staggered at every loop position to eliminate collisions during system retraction.

TOW CHAINS OR TOW ROPES (When Required)

- H.1 Tow chains (or tow ropes) are installed at each loop position and attach to the adjacent trolleys thru the hole at the lower corner of the car body. The chain (or rope) must not be twisted.
- H.2 Tow chains are secured in place by bending the “S” hook loop closed.
- H.3 Tow ropes fasten with a shackle and removable pin.

TOW ARM (Required for Tow Trolley–Figure 4)

- J.1 The tow arm is a device to transmit motion from the customer’s crane or hoist to the tow trolley of the system.
- J.2 The tow arm must protrude thru the rectangular tube far enough to absorb any lateral movement. Clearance within the tube of 1.0" minimum vertically and 0.2" minimum horizontally will compensate for small vertical and larger lateral movements.
- J.3 Check tow arm movement throughout the total system travel to insure it does not pull the tow trolley and there are no upward or downward forces transmitted to the tow trolley.

TENSION ROPES (For Pendant Stations–Figure 5)

- K.1 Tension ropes are used to hang a push-button control below the junction box of a control unit trolley.
- K.2 Eye bolts or loops at one end of the tension ropes fasten to the lower mounting flange of the junction box.
- K.3 The other end fastens to the top of the push-button control.
- K.4 The electric cable must be long enough to zigzag between the tension ropes every few feet to form a lattice arrangement. The cable must not be wrapped around the tension ropes or vice versa. Secure electric cable to tension ropes with electrical tape or nylon ties.
- K.5 A strain relief watertight cable gland assembly is required whenever tension ropes are not utilized.

FUNCTIONAL TESTING

Now that the Festoon System hardware is completely assembled, operate the system throughout its total travel distance by hand and watch for any indications of pinch points or misaligned joints. All problem areas must be corrected.

Initially locate the tow trolley at the storage distance position. The trolley car bumpers must not be in hard contact with one another. A small clearance is designed into the storage area to prevent a forced compression of the trolleys. Move the tow trolley to its furthest point of travel from the end clamp. The system should be fully extended in this position. Check each loop position to see that the cables are suspended uniformly between the trolleys. Tow chains should be suspended in a relaxed state just above the cables in each loop. Tow chains function primarily as a safety feature to eliminate high cable stresses during rapid acceleration rates and high travel speeds.

The Festoon System is now ready for normal operation.

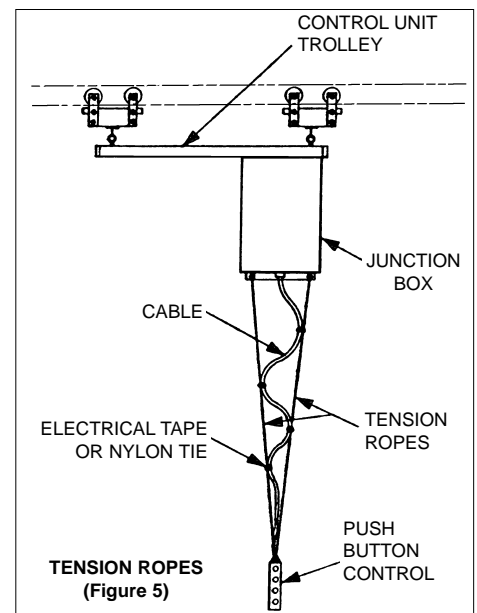
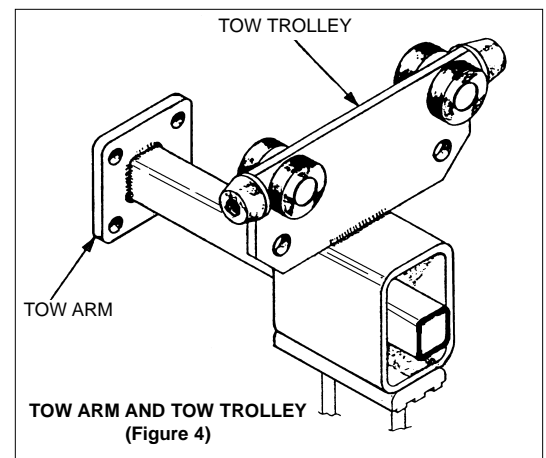
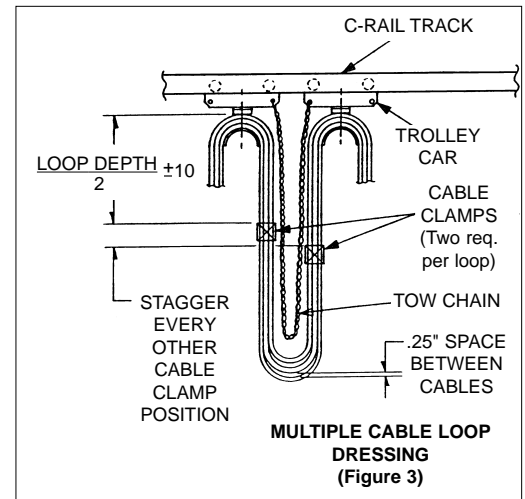

OPERATING & MAINTENANCE INSTRUCTIONS

SYSTEM OPERATION

- A.1 All trolleys must traverse the C-Rail track smoothly. Seizing within a pinched C-Rail section or wheel impacts due to misalignment at a joint can cause premature failure.
- A.2 The slight drag of a trolley car as it is moving thru the C-Rail may indicate friction between the outer side of the wheels and the inner surface of the C-Rail wall. This is not detrimental to the system if the drag is light and the occurrence is intermittent. However, should this drag be continuous, the problem must be corrected as follows:
- A.2.1 The cable package load on the saddles must be balanced at the trolley body to obtain equal loading of all trolley wheels.
 - A.2.2 The lower flanges which support the trolleys must be coplanar and horizontal. Adjust as follows: loosen the C-Rail hanging bracket set screws, rotate the rail until horizontal and shim, if required. Retighten the set screws.
 - A.2.3 The cable loops must be uniform and symmetrical to produce even tension forces between trolleys.
- A.3 When tow chains (or tow ropes) are required on a Festoon System, any high tensile forces normally associated with rapid acceleration rates and high travel speeds are transmitted trolley to trolley by the tow chain. They are designed primarily as a safety device and not intended to be in tension continuously. Tow chains which rapidly pull taut and jerk the trolleys excessively could be caused by the trolley seizing in the C-Rail or the tow chain being too short. Check the tow chain length per the dimension print.
- A.4 The tow arm is a device to transmit movement of the customer's crane or hoist to the tow trolley (lead car). It must have 1.0" minimum of vertical clearance and 0.2" minimum of horizontal clearance within the rectangular tube of the tow trolley and must be perpendicular to the car body to compensate for small vertical and large lateral movements.
- A.5 Tension ropes are used to suspend push button controls beneath the junction box of a control unit trolley for pendant station applications. Two ropes are normally furnished and must be equal in length. The electric cable must be longer than the tension ropes and secured at intervals to form a lattice arrangement. A watertight cable gland is required at the junction box.
- A.6 A Festoon System having many cable loops and trolleys are susceptible to undulating motions during extending of the system. Rapid accelerations, high travel speed, and trolley cars seizing within the C-Rail track are reasons for this behavior. Violent undulations causing tow chains or the cables to tense or snap must be corrected or cable failures are sure to result. Consult factory application engineers for recommendations.

SYSTEM MAINTENANCE

- B.1 C-Rail model Festoon Systems are supplied with precision ball bearing wheels which are greased and sealed for life.
- B.2 The following items are recommended for inspection during a normal equipment check:
- B.2.1 Wear on the trolley car wheels and inside the C-Rail track.
 - B.2.2 Debris within the C-Rail track. Clean out, if necessary, and spray a light film of oil inside the C-Rail to reduce friction and increase rail and wheel life.
 - B.2.3 Separation and misalignment at C-Rail joints.
 - B.2.4 Tightness of nuts and bolts.
 - B.2.5 Condition of trolley bumpers and tow chains or ropes.
 - B.2.6 Clamping of cables at the support saddles and loop clamps.
 - B.2.7 Cable damage.
 - B.2.8 Cable glands for watertight seal effectiveness.
 - B.2.9 Terminal connections in junction box.



GLEASON REEL CORP.
P.O. Box 26 • 600 South Clark St.
Mayville, WI 53050
Phone: 920-387-4120 • Fax: 920-387-4189